

**Verwendung:**

Zur Aufnahme von Einschraubfräser mit Gewinde.

Application:

For mounting screw-in cutters with thread.

Application:

Pour le serrage de fraises à queue filetée.

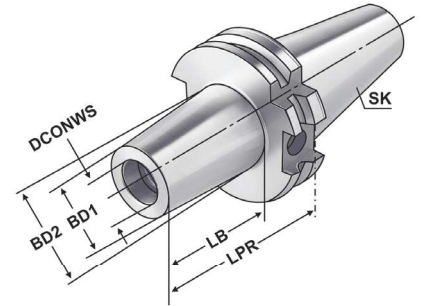

3

ISO 7388-1 DC

Form AD/AF (AD/B)

≤ 3µm

G2.5 25.000 min⁻¹

RFID Chip

H7

Bestell-Nr.
Order no.
Référence

SK

THSZWS

DCONWS

BD1

BD2

LPR

LB

DC.403.06.12	SK-DC 40	M12	12,5	21	24	44	25
DC.403.06.12.1	SK-DC 40	M12	12,5	21	24	69	50
DC.403.06.12.2	SK-DC 40	M12	12,5	21	31	94	75
DC.403.06.16.0	SK-DC 40	M16	17	29	29	24	5
DC.403.06.16	SK-DC 40	M16	17	29	29	44	25
DC.403.06.16.1	SK-DC 40	M16	17	29	34	69	50
DC.403.06.16.2	SK-DC 40	M16	17	29	34	94	75

**Empfohlenes Anzugsmoment
Recommended tightening torques
Torques de serrage recommandés**

M6	10 Nm
M8	25 Nm
M10	40 Nm
M12	60 Nm
M16	50 Nm

